



No gamble with the royal flush



VAM TOP
VAM TOP HC
VAM TOP HT
VAM TOP FE
NEW VAM
VAM ACE
VAM PRO
VAM HW ST
VAM SLIJ II
■ *VAM FJL*
VAM MUST
DINO VAM
BIG OMEGA



VALLOUREC & MANNESMANN TUBES
OCTG DIVISION

External seal geometry

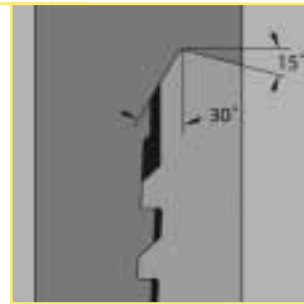

Thread form

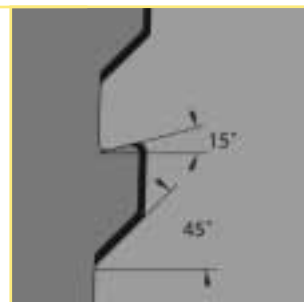

$\text{Ø } 2 \frac{3}{8}'' \text{ to } 11 \frac{7}{8}''$ – 6TPI
Taper 1:16 to 1:10

Internal seal geometry



VAM® FJL (Flush Joint Liner) is a 100% inside and outside flush integral connection providing maximum clearance with optimum strength for liners, moderate depth casing, and tight-hole tubing strings.

BENEFITS

- **Excellent gas-tightness**
- **Maximum clearance (100% flush)**
- **Easy to use and repair**

Integral flush design

- VAM® FJL is an integral connection threaded on plain-end pipe with the OD of the connection totally flush with the pipe body.
- Sizes range from 2 3/8" to 11 7/8" for such clearance applications as tubing in small sizes, drilling liners and tiebacks in medium sizes, and contingency liner in larger casing diameters.

External torque shoulder

- A patented reverse angle external torque shoulder provides a positive torque stop and energizes the external metal-to-metal seal.
- This shoulder also permits visual confirmation of power-tight make-up.

Multiple seal system

- An external seal and an internal seal work independently of each other to achieve sealing against annulus and well bore pressures.
- This multiple seal arrangement ensures gas-tight sealing integrity to 100% of the rated burst and collapse of the pipe body.

Interference tapered thread

- In order to provide optimum strength, the VAM® FJL is designed for 65% to 70% efficiency under tension in medium wall thickness.
- Thread load flank has a 15° reverse angle to resist jump-out.
- Thread stabbing flank has a 45° angle for fast, trouble-free make-up.
- The design of VAM® FJL exhibits an exceptional bending resistance for a connection of this class.

Streamlined internal and external profile

- The OD and ID are 100% flush (there is no upset).
- The ID is bored and recess-free for smooth, efficient flow.
- The OD is turned to tight tolerances.
- VAM® FJL can be repaired by VAM® licensed workshops. Only slight pin end swaging is needed for machining threads.

Joint yield strengths are calculated from the minimum specified material yield stress and the critical joint cross sectional area, pipe or coupling, as appropriate.

Size (OD)	Nominal weight	Pipe							Connection		Tensile performance (1000 lb.)						
		Plain end weight	Wall thickness		ID nominal	Drift diameter	Pin ID	Pin length	Joint critical cross section	Joint tensile efficiency	Parting Load						
			in.	mm							in.	in.	in.	in.	sq. in.	%	L80
inch mm	lb./ft.	lb./ft.	in.	mm	in.	in.	in.	in.	sq. in.	%	L80	N80	C95	P110	Q125	140	150
2 3/8 60.33	4.60	4.43	0.190	4.83	1.995	1.901	1.933	1.890	0.586 P	45	56	59	62	73	79	88	94
	5.10	5.02	0.218	5.54	1.939	1.845	1.878	2.283	0.760 P	51	72	76	80	95	103	114	122
	5.80	5.75	0.254	6.45	1.867	1.773	1.811	2.992	0.936 B	55	89	94	98	117	126	140	150
	6.30	6.26	0.280	7.11	1.815	1.721	1.764	2.874	1.015 B	55	96	102	107	127	137	152	162
	7.35	7.32	0.336	8.53	1.703	1.609	1.654	3.701	1.183 B	55	112	118	124	148	160	177	189
2 7/8 73.03	6.40	6.16	0.217	5.51	2.441	2.347	2.382	2.244	0.887 P	49	84	89	93	111	120	133	142
	7.80	7.66	0.276	7.01	2.323	2.229	2.276	2.913	1.172 B	52	111	117	123	146	158	176	188
	8.60	8.44	0.308	7.82	2.259	2.165	2.213	3.071	1.378 P	55	131	138	145	172	186	207	220
	9.80	9.72	0.362	9.19	2.151	2.057	2.106	3.819	1.573 B	55	149	157	165	197	212	236	252
	10.70	10.68	0.405	10.29	2.065	1.971	2.020	5.787	2.038 P	65	194	204	214	255	275	306	326
3 1/2 88.90	7.70	7.58	0.216	5.49	3.068	2.943	3.016	2.126	1.059 P	48	101	106	111	132	143	159	169
	9.20	8.81	0.254	6.45	2.992	2.867	2.941	2.756	1.420 P	55	135	142	149	177	192	213	227
	10.20	9.91	0.289	7.34	2.922	2.797	2.858	3.307	1.598 B	55	152	160	168	200	216	240	256
	12.70	12.52	0.375	9.53	2.750	2.625	2.673	3.976	2.390 P	65	227	239	251	299	323	359	382
	13.70	13.62	0.413	10.49	2.674	2.549	2.594	4.449	2.713 B	68	258	271	285	339	366	407	434
	14.70	14.63	0.449	11.40	2.602	2.477	2.524	4.921	2.931 B	68	278	293	308	366	396	440	469
	15.50	15.37	0.476	12.09	2.548	2.423	2.472	5.236	3.075 B	68	292	308	323	384	415	461	492
4 101.60	9.50	9.11	0.226	5.74	3.548	3.423	3.480	2.205	1.288 P	48	122	129	135	161	174	193	206
	10.90	10.46	0.262	6.65	3.476	3.351	3.398	2.795	1.685 P	55	160	168	177	211	227	253	270
	11.30	11.34	0.286	7.26	3.428	3.303	3.374	3.180	1.837 B	55	174	184	193	230	248	276	294
	13.20	12.93	0.330	8.38	3.340	3.215	3.260	2.992	2.093 P	55	199	209	220	262	282	314	335
	14.80	14.69	0.380	9.65	3.240	3.115	3.165	3.780	2.610 P	60	248	261	274	326	352	392	418
	16.50	16.39	0.430	10.92	3.140	3.015	3.063	4.409	3.111 P	65	296	311	327	389	420	467	498
	17.00	16.72	0.380	9.65	3.740	3.615	3.673	3.701	3.112 P	63	296	311	327	389	420	467	498
4 1/2 114.3	11.60	11.35	0.250	6.35	4.000	3.875	3.917	2.559	1.533 P	46	146	153	161	192	207	230	245
	12.60	12.24	0.271	6.88	3.958	3.833	3.878	2.559	1.796 P	50	171	180	189	225	243	269	287
	13.50	13.04	0.290	7.37	3.920	3.795	3.843	2.559	2.031 P	53	193	203	213	254	274	305	325
	15.10	14.98	0.337	8.56	3.826	3.701	3.756	3.189	2.602 P	59	247	260	273	325	351	390	416
	17.00	16.72	0.380	9.65	3.740	3.615	3.673	3.701	3.112 P	63	296	311	327	389	420	467	498
	18.90	18.69	0.430	10.92	3.640	3.515	3.575	4.291	3.577 B	65	340	358	376	447	483	537	572
	21.50	21.36	0.500	12.70	3.500	3.375	3.453	5.118	4.086 B	65	388	409	429	511	552	613	654
	23.70	23.56	0.560	14.22	3.380	3.255	3.335	5.827	4.514 B	65	429	451	474	564	609	677	722
5 127.00	13.00	12.83	0.253	6.43	4.494	4.369	4.417	2.795	2.079 B	55	197	208	218	260	281	312	333
	15.00	14.87	0.296	7.52	4.408	4.283	4.431	3.504	2.407 B	55	229	241	253	301	325	361	385
	18.00	17.93	0.362	9.19	4.276	4.151	4.209	3.425	3.205 P	61	305	321	337	401	433	481	513
	20.30	20.01	0.408	10.36	4.184	4.059	4.118	4.213	3.818 P	65	363	382	401	477	515	573	611
	20.80	20.63	0.422	10.72	4.156	4.031	4.091	4.213	3.999 B	66	380	400	420	500	540	600	640
	21.40	21.30	0.437	11.10	4.126	4.001	4.079	4.331	4.083 B	65	388	408	429	510	551	612	653
	23.20	23.08	0.478	12.14	4.044	3.919	3.996	5.039	4.574 B	67	435	457	480	572	617	686	732
	24.10	24.03	0.500	12.70	4.000	3.875	3.957	5.039	4.574 B	65	435	457	480	572	617	686	732
	29.70	29.64	0.562	14.27	4.376	4.251	4.317	5.709	5.690 B	65	541	569	597	711	768	854	910
5 1/2 139.70	15.50	15.35	0.275	6.99	4.950	4.825	4.874	2.874	2.488 P	55	236	249	261	311	336	373	398
	17.00	16.87	0.304	7.72	4.892	4.767	4.823	3.346	2.736 B	55	260	274	287	342	369	410	438
	20.00	19.81	0.361	9.17	4.778	4.653	4.709	3.386	3.416 P	59	325	342	359	427	461	512	547
	23.00	22.54	0.415	10.54	4.670	4.545	4.602	4.252	4.218 P	64	401	422	443	527	569	633	675
	26.00	25.54	0.476	12.09	4.548	4.423	4.500	4.843	5.031 B	67	478	503	528	629	679	755	805
	28.40	28.13	0.530	13.46	4.440	4.315	4.390	5.315	5.391 B	65	512	539	566	674	728	809	863
	29.70	29.64	0.562	14.27	4.376	4.251	4.317	5.709	5.690 B	65	541	569	597	711	768	854	910
	35.00	34.20	0.525	13.34	5.575	5.450	5.528	5.512	6.778 B	67	644	678	712	847	915	1017	1084
6 5/8 168.28	23.20	23.58	0.330	8.94	5.965	5.796	5.898	2.953	3.579 P	55	340	358	376	447	483	537	573
	24.00	23.58	0.352	8.94	5.921	5.796	5.858	2.953	3.991 P	58	379	399	419	499	539	599	639
	28.00	27.65	0.417	10.59	5.791	5.666	5.732	3.976	5.186 P	64	493	519	545	648	700	778	830
	32.00	31.20	0.475	12.07	5.675	5.550	5.630	4.724	6.039 B	66	574	604	634	755	815	906	966
	35.00	34.20	0.525	13.34	5.575	5.450	5.528	5.512	6.778 B	67	644	678	712	847	915	1017	1084

A: Alternate drift

P = Pin, B = Box

1000 lb. = 4.44822 kN

External pressure equal to collapse pressure calculated from API Bul. 5 C 3 section 1. Minimum internal yield pressure are calculated from API Bul. 5 C 3 section 3, formula 3.1.1.

External pressure (psi)						Minimum internal yield pressure (psi)						Nominal weight	Size (OD)
80 ksi	95 ksi	110 ksi	125 ksi	140 ksi	150 ksi	80 ksi	95 ksi	110 ksi	125 ksi	140 ksi	150 ksi	lb./ft.	inch mm
11780	13980	16130	17900	19580	20660	11200	13300	15400	17500	19600	21000	4.60	2 3/8
13340	15840	18340	20840	23340	25010	12850	15260	17670	20080	22490	24090	5.10	60.33
15280	18150	21010	23880	26740	28650	14970	17780	20590	23390	26200	28070	5.80	
16640	19760	22880	26000	29120	31200	16510	19600	22690	25790	28880	30950	6.30	
19430	23080	26720	30360	34010	36440	19810	23520	27230	30950	34660	37140	7.35	
11170	12940	14550	16070	17490	18400	10570	12550	14530	16510	18490	19810	6.40	2 7/8
13890	16490	19090	21700	24300	26040	13440	15960	18480	21000	23520	25200	7.80	73.03
15300	18170	21040	23910	26780	28700	15000	17810	20620	23430	26250	28120	8.60	
17610	20910	24210	27510	30820	33020	17630	20930	24240	27540	30850	33050	9.80	
19360	22990	26630	30260	33890	36310	19720	23420	27120	30820	34510	36980	10.70	
7870	8850	9730	10500	11140	11510	8640	10260	11880	13500	15120	16200	7.70	3 1/2
10540	12080	13530	14890	16150	16940	10160	12070	13970	15880	17780	19050	9.20	88.90
12120	14390	16670	18940	20770	21950	11560	13730	15900	18060	20230	21680	10.20	
15310	18180	21050	23920	26790	28700	15000	17810	20630	23440	26250	28130	12.70	
16650	19770	22900	26020	29140	31220	16520	19620	22720	25810	28910	30980	13.70	
17890	21250	24600	27960	31310	33550	17960	21330	24700	28060	31430	33680	14.70	
18800	22330	25850	29380	32900	35250	19040	22610	26180	29750	33320	35700	15.50	
6590	7310	7910	8390	8730	8900	7910	9390	10880	12360	13840	14830	9.50	4
8800	9980	11060	12030	12890	13400	9170	10890	12610	14330	16050	17190	10.90	101.60
10280	11760	13160	14460	15660	16410	10010	11890	13760	15640	17520	18770	11.30	
12110	14380	16650	18910	20740	21910	11550	13720	15880	18050	20210	21660	13.20	
13760	16340	18910	21490	24070	25790	13300	15790	18290	20780	23280	24940	14.80	
15350	18230	21110	23990	26860	28780	15050	17870	20690	23520	26340	28220	16.50	
6360	7030	7580	8000	8300	8430	7780	9240	10690	12150	13610	14580	11.60	4 1/2
7500	8410	9210	9890	10450	10760	8430	10010	11590	13170	14750	15810	12.60	114.3
8540	9660	10690	11600	12400	12880	9020	10710	12410	14100	15790	16920	13.50	
11080	12760	14340	15830	17220	18100	10480	12450	14420	16380	18350	19660	15.10	
12370	14690	17010	19330	21630	22890	11820	14040	16260	18470	20690	22170	17.00	
13830	16420	19010	21610	24200	25930	13380	15890	18390	20900	23410	25080	18.90	
15800	18770	21730	24690	27650	29630	15560	18470	21390	24310	27220	29170	21.50	
17430	20700	23970	27240	30510	32690	17420	20690	23960	27220	30490	32670	23.70	
5140	5550	5840	6050	6350	6520	7080	8410	9740	11070	12400	13280	13.00	5
7250	8110	8850	9480	9980	10250	8290	9840	11400	12950	14500	15540	15.00	127.00
10500	12020	13470	14820	16070	16860	10140	12040	13940	15840	17740	19010	18.00	
11990	14240	16490	18550	20320	21460	11420	13570	15710	17850	19990	21420	20.30	
12360	14680	17000	19320	21610	22860	11820	14030	16250	18460	20680	22160	20.80	
12760	15150	17550	19940	22330	23930	12240	14530	16820	19120	21410	22940	21.40	
13830	16430	19020	21620	24210	25940	13380	15890	18400	20910	23420	25100	23.20	
14400	17100	19800	22500	25200	27000	14000	16630	19250	21880	24500	26250	24.10	
4990	5380	5630	5890	6170	6320	7000	8310	9630	10940	12250	13130	15.50	5 1/2
6290	6940	7480	7890	8170	8290	7740	9190	10640	12090	13540	14510	17.00	139.70
8830	10020	11110	12090	12950	13470	9190	10910	12640	14360	16080	17230	20.00	
11160	12930	14540	16060	17480	18390	10560	12540	14530	16510	18490	19810	23.00	
12650	15020	17390	19760	22140	23720	12120	14390	16660	18930	21200	22720	26.00	
13930	16540	19160	21770	24380	26120	13490	16020	18550	21080	23610	25300	28.40	
14680	17430	20180	22940	25690	27520	14310	16990	19670	22350	25030	26820	29.70	
4940	5320	5570	5840	6120	6260	6970	8280	9590	10900	12200	13080	23.20	6 5/8
5760	6310	6730	7020	7180	7340	7440	8830	10230	11620	13020	13950	24.00	168.28
8170	9220	10160	11000	11710	12120	8810	10460	12120	13770	15420	16520	28.00	
10320	11830	13230	14540	15750	16510	10040	11920	13800	15680	17570	18820	32.00	
11670	13860	15870	17600	19230	20280	11090	13170	15250	17330	19420	20800	35.00	

1 ksi = 1000 psi
1 psi = 0.006895 Mpa
0.06895 bar

Joint yield strengths are calculated from the minimum specified material yield stress and the critical joint cross sectional area, pipe or coupling, as appropriate.

Size (OD)	Nominal weight	Pipe							Connection		Tensile performance (1000 lb.)						
		Plain end weight	Wall thickness		ID nominal	Drift diameter	Pin ID	Pin length	Joint critical cross section	Joint tensile efficiency	Parting load						
			lb./ft.	in.							mm	in.	in.	sq. in.	%	L80	N80
inch mm	lb./ft.	lb./ft.	in.	mm	in.	in.	in.	in.	sq. in.	%	L80	N80	C95	P110	Q125	140	150
7 177.8	23.00	22.63	0.317	8.05	6.366	6.250 A	6.299	2.638	3.401 P	51	323	340	357	425	459	510	544
	26.00	25.66	0.362	9.19	6.276	6.151	6.213	3.150	4.297 P	57	408	430	451	537	580	645	688
	29.00	28.72	0.408	10.36	6.184	6.059	6.122	3.701	5.199 P	62	494	520	546	650	702	780	832
	32.00	31.67	0.453	11.51	6.094	6.000 A	6.035	4.291	6.064 P	65	576	606	637	758	819	910	970
	35.00	34.58	0.498	12.65	6.004	5.879	5.957	4.843	6.642 B	65	631	664	697	830	897	996	1063
	38.00	37.26	0.540	13.72	5.920	5.795	5.874	5.354	7.152 B	65	679	715	751	894	965	1073	1144
	41.00	40.39	0.590	14.99	5.820	5.695	5.772	5.945	7.735 B	65	735	773	812	967	1044	1160	1238
7 5/8 193.68	26.40	25.56	0.328	8.33	6.969	6.844	6.906	2.638	3.892 P	52	370	389	409	487	525	584	623
	29.70	29.04	0.375	9.53	6.875	6.750	6.815	3.228	4.910 P	57	466	491	516	614	663	737	786
	33.70	33.04	0.430	10.92	6.765	6.640	6.709	3.937	6.092 P	63	579	609	640	761	822	914	975
	35.80	35.56	0.465	11.81	6.695	6.570	6.646	4.370	6.822 B	65	648	682	716	853	921	1023	1092
	39.00	38.05	0.500	12.70	6.625	6.500	6.575	4.803	7.297 B	65	693	730	766	912	985	1095	1168
	42.80	42.39	0.562	14.27	6.501	6.376	6.453	5.551	8.114 B	65	771	811	852	1014	1095	1217	1298
	45.30	44.67	0.595	15.11	6.435	6.310	6.386	6.063	8.669 B	66	824	867	910	1084	1170	1300	1387
	47.10	46.73	0.625	15.88	6.375	6.250	6.323	5.906	9.063 B	66	861	906	952	1133	1223	1359	1450
8 5/8 219.08	32.00	31.10	0.352	8.94	7.921	7.875 A	7.862	2.874	4.985 P	54	474	498	523	623	673	748	798
	36.00	35.14	0.400	10.16	7.825	7.700	7.768	3.583	6.167 P	60	586	617	648	771	833	925	987
	40.00	39.29	0.450	11.43	7.725	7.625 A	7.673	4.370	7.389 P	64	702	739	776	924	997	1108	1182
	44.00	43.39	0.500	12.70	7.625	7.500	7.583	4.803	8.347 B	65	793	835	876	1043	1127	1252	1336
	49.00	47.99	0.557	14.15	7.511	7.386	7.469	5.945	9.768 B	69	928	977	1026	1221	1319	1465	1563
	52.00	51.03	0.595	15.11	7.435	7.310	7.394	5.945	9.768 B	65	928	977	1026	1221	1319	1465	1563
9 5/8 244.48	36.00	34.86	0.352	8.94	8.921	8.765	8.331	2.992	5.484 P	53	521	548	576	685	740	823	877
	40.00	38.94	0.395	10.03	8.835	8.750 A	8.748	3.780	6.681 P	58	635	668	701	835	902	1002	1069
	43.50	42.69	0.435	11.05	8.755	8.599	8.669	4.370	7.784 P	62	739	778	817	973	1051	1168	1245
	47.00	46.14	0.472	11.99	8.681	8.525	8.638	4.370	8.798 P	65	836	880	924	1100	1188	1320	1408
	53.50	52.85	0.545	13.84	8.535	8.500 A	8.567	5.276	10.126 B	65	962	1013	1063	1266	1367	1519	1620
	58.40	57.38	0.595	15.11	8.435	8.375 A	8.362	6.260	11.499 B	68	1092	1150	1207	1437	1552	1725	1840
	59.40	58.64	0.609	15.47	8.407	8.251	8.362	6.626	11.499 B	67	1092	1150	1207	1437	1552	1725	1840
	61.10	60.08	0.625	15.88	8.375	8.219	8.362	6.260	11.499 B	65	1092	1150	1207	1437	1552	1725	1840
9 7/8 250.83	62.80	61.74	0.625	15.88	8.625	8.469	8.579	6.260	12.372 B	68	1175	1237	1299	1547	1670	1856	1980
	66.40	65.05	0.661	16.79	8.553	8.397	8.579	6.260	12.372 B	65	1175	1237	1299	1547	1670	1856	1980
	67.50	66.60	0.678	17.22	8.519	8.363	8.457	6.732	13.042 B	67	1239	1304	1369	1630	1761	1956	2087
10 3/4 273.05	40.50	38.88	0.350	8.89	10.050	9.894	9.969	2.874	5.981 P	52	568	598	628	748	807	897	957
	45.50	44.22	0.400	10.16	9.950	9.875 A	9.866	3.858	7.553 P	58	718	755	793	944	1020	1133	1208
	51.00	49.50	0.450	11.43	9.850	9.694	9.768	4.606	9.108 P	63	865	911	956	1138	1230	1366	1457
	55.50	54.21	0.495	12.57	9.760	9.625 A	9.685	4.606	10.401 B	65	988	1040	1092	1300	1404	1560	1664
	60.70	59.40	0.545	13.84	9.660	9.504	9.587	5.276	11.461 B	66	1089	1146	1203	1433	1547	1719	1834
65.70	64.53	0.595	15.11	9.560	9.404	9.488	5.906	12.451 B	66	1183	1245	1307	1556	1681	1868	1992	
11 3/4 298.45	47.00	45.56	0.375	9.53	11.000	10.844	10.961	3.386	7.488 B	56	711	749	786	936	1011	1123	1198
	54.00	52.57	0.435	11.05	10.880	10.724	10.835	4.961	9.233 B	60	877	923	970	1154	1247	1385	1477
	60.00	58.81	0.489	12.42	10.772	10.625 A	10.717	4.252	10.985 B	63	1044	1098	1153	1373	1483	1648	1758
	65.00	63.97	0.534	13.56	10.682	10.625 A	10.701	4.921	12.152 B	65	1154	1215	1276	1519	1641	1823	1944
11 7/8 301.63	71.80	70.19	0.582	14.78	10.711	10.555	10.740	5.630	13.514 B	65	1284	1351	1419	1689	1824	2027	2162

A: Alternate drift

P = Pin, B = Box

1000 lb. = 4.44822 kN

External pressure equal to collapse pressure calculated from API Bul. 5 C 3 section 1. Minimum internal yield pressure are calculated from API Bul. 5 C 3 section 3, formula 3.1.1.

External pressure (psi)						Minimum internal yield pressure (psi)						Nominal weight	Size (OD)
80 ksi	95 ksi	110 ksi	125 ksi	140 ksi	150 ksi	80 ksi	95 ksi	110 ksi	125 ksi	140 ksi	150 ksi	lb./ft.	inch mm
3830	4150	4430	4650	4760	4780	6340	7530	8720	9910	11100	11890	23.00	7
5410	5890	6230	6450	6690	6880	7240	8600	9960	11310	12670	13580	26.00	177.8
7030	7840	8530	9110	9560	9790	8160	9690	11220	12750	14280	15300	29.00	
8610	9740	10780	11710	12530	13010	9060	10760	12460	14160	15860	16990	32.00	
10190	11650	13030	14320	15490	16230	9960	11830	13700	15560	17430	18680	35.00	
11390	13430	15130	16740	18260	19230	10800	12830	14850	16880	18900	20250	38.00	
12350	14660	16980	19300	21560	22810	11800	14010	16230	18440	20650	22130	41.00	
3400	3710	3920	4050	4080	4080	6020	7150	8280	9410	10540	11290	26.40	7 5/8
4790	5130	5350	5670	5930	6050	6890	8180	9470	10760	12050	12910	29.70	193.68
6560	7270	7870	8340	8690	8850	7900	9380	10860	12340	13820	14800	33.70	
7690	8640	9480	10200	10800	11140	8540	10140	11740	13340	14940	16010	35.80	
8820	10000	11080	12060	12920	13440	9180	10900	12620	14340	16070	17210	39.00	
10820	12410	13930	15350	16680	17510	10320	12250	14190	16120	18060	19350	42.80	
11510	13670	15440	17100	18670	19680	10920	12970	15020	17070	19120	20480	45.30	
12040	14300	16550	18700	20490	21650	11480	13630	15780	17930	20080	21520	47.10	
3040	3280	3420	3470	3470	3470	5710	6780	7860	8930	10000	10710	32.00	8 5/8
4100	4360	4680	4930	5080	5140	6490	7710	8930	10140	11360	12170	36.00	219.08
5530	6020	6400	6640	6830	7030	7300	8670	10040	11410	12780	13700	40.00	
6950	7740	8420	8980	9410	9640	8120	9640	11160	12680	14200	15220	44.00	
8570	9700	10740	11660	12460	12940	9040	10740	12430	14130	15820	16950	49.00	
9660	11010	12280	13440	14500	15150	9660	11470	13280	15090	16900	18110	52.00	
2370	2470	2470	2470	2470	2470	5120	6080	7040	8000	8960	9600	36.00	9 5/8
3080	3330	3470	3530	3530	3530	5750	6820	7900	8980	10050	10770	40.00	244.48
3810	4130	4410	4620	4730	4750	6330	7510	8700	9890	11070	11860	43.50	
4760	5090	5300	5630	5880	6010	6870	8150	9440	10730	12010	12870	47.00	
6620	7340	7950	8440	8790	8960	7930	9410	10900	12390	13870	14860	53.50	
7900	8880	9770	10540	11190	11560	8650	10280	11900	13520	15150	16230	58.40	
8250	9320	10280	11130	11860	12290	8860	10520	12180	13840	15500	16610	59.40	
8660	9810	10860	11800	12630	13120	9090	10800	12500	14200	15910	17050	61.10	
8260	9320	10290	11140	11870	12300	8860	10520	12180	13840	15510	16610	62.80	9 7/8
9150	10400	11560	12610	13550	14130	9370	11130	12890	14640	16400	17570	66.40	250.83
9580	10910	12160	13310	14350	14990	9610	11410	13220	15020	16820	18020	67.50	
1730	1730	1730	1730	1730	1730	4560	5410	6270	7120	7980	8550	40.50	10 3/4
2470	2590	2610	2610	2610	2610	5210	6190	7160	8140	9120	9770	45.50	273.05
3210	3490	3660	3740	3750	3750	5860	6960	8060	9160	10260	10990	51.00	
4020	4290	4610	4850	4990	5030	6450	7660	8860	10070	11280	12090	55.50	
5160	5580	5880	6070	6390	6550	7100	8430	9760	11090	12420	13310	60.70	
6310	6960	7510	7920	8200	8320	7750	9200	10650	12110	13560	14530	65.70	
1630	1630	1630	1630	1630	1630	4470	5310	6140	6980	7820	8380	47.00	11 3/4
2440	2550	2570	2570	2570	2570	5180	6150	7130	8100	9070	9720	54.00	298.45
3170	3440	3600	3680	3680	3680	5830	6920	8010	9100	10200	10920	60.00	
3870	4180	4470	4690	4800	4840	6360	7560	8750	9940	11130	11930	65.00	
4750	5080	5290	5630	5880	6000	6860	8150	9430	10720	12010	12870	71.80	11 7/8
													301.63

1 ksi = 1000 psi
 1 psi = 0.006895 Mpa
 0.06895 bar

Our worldwide network for your success



VALLOUREC MANNESMANN OIL & GAS FRANCE
Sales and Technical Sales
130, rue de Sully
92100 Boulogne-Billancourt
France
Phone +33 1 49093586
Fax +33 1 49093713

VALLOUREC MANNESMANN OIL & GAS GERMANY GmbH
Sales and Technical Sales
Theodorstrasse 90
40472 Düsseldorf
Germany
Phone +49 211 960-0
Fax +49 211 960-3924

VALLOUREC MANNESMANN OIL & GAS UK Ltd.
Ocean Spirit House, Prospect Point
33 Waterloo Quay
Aberdeen, UK AB11 5BS
Phone +44 1224 564000
Fax +44 1224 564007

VALLOUREC & MANNESMANN TUBES CORP.
1990 Post Oak Blvd, Suite 1400
Houston, TX 77056-3813, USA
Phone +1 713 4793200
Fax +1 713 4793201

VAM PTS
19210 Hardy Road
Houston, TX 77073
USA
Phone +1 281 8215510
Fax +1 281 8217760

V&M STAR
8603 Sheldon Road
Houston, TX 77049, USA
Phone +1 281 4566000
Fax +1 281 4567247

VAM PC
1800, 444 – 5th Avenue SW
Calgary, Alberta
Canada T2P 2T8
Phone +1 403 2330119
Fax +1 403 2662332

PRINVER
Av. Framboyantes Lote 6, Manzana 5
Cd. ind. Bruno Pagliai
Tejeria, Vera Cruz
CP 91697
Phone +52 29 898727
Fax +52 29 898734

V & M do BRASIL
Rua Lauro Müller 116 – Sala 2508
Botafogo 22290-160
Rio de Janeiro - RJ
Brazil
Phone + 55 21 38738300
Fax + 55 21 38738316

VAM Field Service International
Ocean Spirit House, Prospect Point
33 Waterloo Quay
Aberdeen, UK AB11 5BS
Phone +44 1224 585331
Fax +44 1224 583491

VALLOUREC MANNESMANN OIL & GAS
Middle East Office
World Trade Center
6th Floor, suite 604
P.O. Box 9405
Dubai, U.A.E.
Phone +971 4 329 16 18
Fax +971 4 329 16 22

VAM FAR EAST PTE Ltd.
593 Havelock Road #01-03
Isetan Office Building
Singapore 169641
Phone +65 6736 23 72
Fax +65 6235 11 26

VAM SERVICES Licensee Network
OCTG Division
21-23 rue de Leval
59620 Aulnoye Aymeries
France
Phone +33 3 27696615
Fax +33 3 27664575



Procedure to get CDS (Connection Data Sheet) on the website:

Click anywhere in the picture. Click [Product Catalogue](#) / pipe and VAM connection data. Click the appropriate combination of size/connection. Click on [Internet](#). Under "Make-up properties", click on **CDS**.

www.vamservices.com



VALLOUREC & MANNESMANN TUBES
OCTG DIVISION